



SIMPLY

Vertical machine
Macchina verticale
Machine verticale



**BREAK THE LIMITS,
BE UNBREAKABLE.**



**SIMPLE, ECONOMIC, EASY...
SIMPLY!**

**The name says it all, doesn't it?
Simply is simple, inexpensive
and easy to use. It is essential
and reliable, capable of "big"
machine performance.**

*Il nome dice tutto, vero?
È semplicemente semplice, poco
costosa e di facile utilizzo.
È essenziale e affidabile, capace di
prestazioni da "grande" macchina.*

*Le nom dit tout, n'est-ce pas?
Simply est simple, peu coûteux et
facile à utiliser. Il est essentiel et
fiable, et offre des performances de
«grande» machine.*



SIMPLY

Vertical machine
Macchina verticale
Machine verticale



● WHY SIMPLY?

- Simple, inexpensive, and easy to use.
- It is essential and reliable, capable of "big" machine performance.
- Can memorize 1 wrapping cycle to client requirements.

● PERCHÈ SIMPLY?

- Semplice, economica e facile da usare.
- È essenziale e affidabile, capace di prestazioni da "grande" macchina.
- Può memorizzare 1 ciclo di avvolgimento in base alle esigenze del cliente.

● POURQUOI SIMPLY?

- Simple, économique et facile à utiliser.
- Elle est essentielle et fiable, en offrant les performances d'une « grande » machine.
- Elle peut mémoriser 1 cycle de banderolage selon les exigences du client.

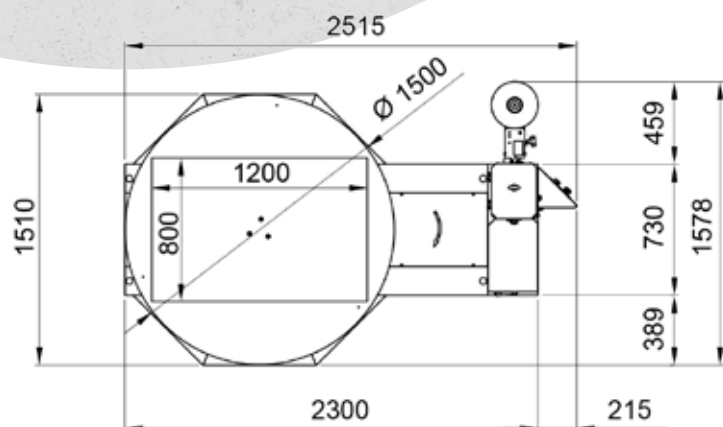
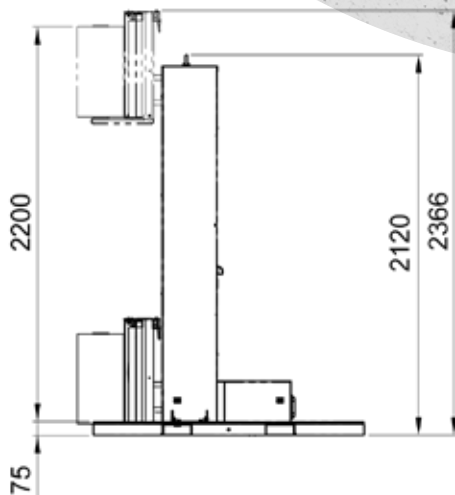

Available with carriage

Disponibile con carrello

Disponible avec chariot



MB

Mechanical brake

Freno meccanico

Frein mécanique



OPTIONAL

INDUSTRY 4.0

OPTIONAL

Manual roping device

Cordonatura manuale

Dispositif de cordage manuel



Control panel

Quadro comandi

Tableau de commande

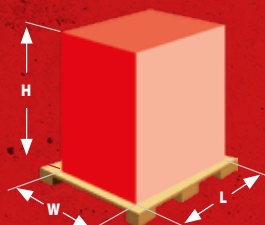

SIMPLY		
Ø	1500	1650
L	1200	1200
W	800	1000
H	2200	2200
KG	2000	2000

SIMPLY



Web app for the management control of the state of machines, assistance, rental, etc.

Applicativo web per il controllo gestionale dello stato macchine, assistenza, noleggio, ecc

Application web pour le contrôle de gestion de l'état de la machine, de l'assistance, de la location, etc.

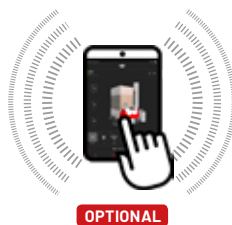

"DeTouch" Technology for remote control and monitoring of your machines with any mobile device.

Tecnologia "DeTouch" per il controllo e monitoraggio della macchina da remoto con ogni dispositivo.

Technologie "DeTouch" pour le contrôle et la surveillance à distance de vos machines avec n'importe quel appareil mobile..

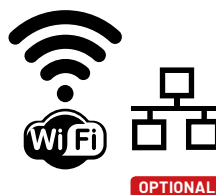

Remote control of all parameters from PC, Tablet or Smartphone

Controllo remoto di tutti i parametri tramite PC, Tablet o Smartphone

Contrôle à distance de tous les paramètres via un PC, une tablette ou un smartphone.

TECHNICAL FEATURES

- Gradual rotation start/stop controllable by inverter
- Carriage up/down speed controllable by independent inverter
- Acoustic signal at cycle start and stopping in phase at cycle end
- Emergency stop button compliant with CE standards
- Machine reset button compliant with CE standards
- Emergency/safety stop at base of reel holder carriage

CARATTERISTICHE TECNICHE

- Partenza/arresto della rotazione graduale e regolabile con inverter
- Velocità salita/discesa carrello regolabile con inverter indipendente
- Segnale acustico avvio ciclo e fermata in fase a fine ciclo
- Pulsante a fungo di emergenza secondo norme CE
- Pulsante di riarmo macchina in funzione secondo norme CE
- Arresto di emergenza /sicurezza posto alla base del carrello porta bobina

CARACTERISTIQUES TECHNIQUES

- Démarrage/arrêt de la rotation progressive et réglable par inverseur
- Vitesse du chariot réglable en montée et en descente avec inverseur indépendant
- Signal acoustique de début de cycle et d'arrêt en fin de cycle
- Bouton coup de poing d'urgence conforme aux normes CE
- -Bouton de réinitialisation de la machine en marche selon les normes CE
- Arrêt d'urgence/sécurité à la base du chariot porte-bobines

PARAMETERS ADJUSTABLE FROM CONTROL PANEL

- Separate number of wraps on pallet top/bottom
- Variable rotation speed
- Separate carriage up/down speeds
- Photocell sensing delay
- Buttons for manual machine operation
- Display for operating values

PARAMETRI REGOLABILI DA QUADRO COMANDI

- Giri separati alla base/sommità del pallet
- Velocità rotazione regolabile
- Velocità separate salita/ discesa del carrello
- Ritardo lettura fotocellula
- Pulsanti di gestione manuale della macchina
- Visualizzatore di quote

PARAMETRES REGULABLES DEPUIS LE TABLEAU DE COMMANDE

- Tours à la base et au sommet de la palette séparés
- Vitesse de rotation réglable
- Vitesses de montée et descente du chariot séparées
- Retard de lecture de la photocellule
- Boutons de gestion manuelle de la machine
- Afficheur de cotes

STANDARD CYCLES SELECTABLE FROM PANEL

- Up and down
- Up or down only
- Manual cycle

CICLI BASE SELEZIONABILI DA QUADRO

- Ciclo salita e discesa
- Ciclo solo salita/solo discesa
- Ciclo manuale

CYCLES DE BASE SELECTIONNABLES DEPUIS LE PANNEAU

- Cycle montée et descente
- Cycle seule montée/descente
- Cycle manuel

ADDITIONAL FUNCTIONS FOR STANDARD CYCLES

- Top sheet application
- Wrapping cycle with display for values
- Reinforcement wraps with manual button

FUNZIONI ATTIVABILI SU CICLO BASE

- Ciclo mettifoglio
- Ciclo con visualizzatore di quote
- Avvolgimenti di rinforzo con pulsante manuale

FONCTIONS ACTIVABLES SUR CYCLE DE BASE

- Cycle dépose de coiffe
- Cycle avec afficheur de cotes
- Banderolage de renfort avec bouton manuel



BREAK THE LIMITS,
BE UNBREAKABLE.

PKG s.r.l.
Via Torriane, 58
47824 Poggio Torriana (RN) Italy

Tel. +39 0541 627063 _ Fax +39 0541 675448
info@pkg-group.com

www.pkg-group.com

